

WISE-6610P

16ch Industrial LoRaWAN Gateway

NEW



Features

- 16ch with Latest Semtech SX1302 gateway chipset solution, it doubles the packet processing speed
- Embedded LoRaWAN Network Server for both private and public system application
- Compatible with Multiple Network Servers like Activity, The Things Network, Chirpstack, AWS, etc
- Supports Modbus/TCP, MQTT, BacNet, OPCUA protocols
- Build-in Node-Red, LoRaWAN network server and Edgmlink software packages
- Global LoRaWAN Frequency Plans
- Pole and wall mounting design
- IEEE 802.3af compliant from PoE equipment

Introduction

The WISE-6610P is the next generation of Industrial LoRaWAN Gateway with 16 wireless communication channel and IP67 rating enclosure design. It has high-performance that offers reliable connectivity for industrial environments. It supports the LoRaWAN protocol for building LoRaWAN private and public networks, as well as various industrial protocols including Modbus, OPCUA, Backnet/IP, MQTT, etc. The hardware and software flexibility of the WISE-6610P provides rich features for edge intelligence systems, and also supports VPN tunneling with various protocols ensures safe communications. The WISE-6610P also runs an embedded LoRaWAN network server (LNS) that can decode the LoRaWAN data directly in our device.

Specifications

WSN Support

- **Standard** LoRaWAN
- **Frequency** IN865/EU868/AU915/US915/KR920/AS923/JP923
- **Frequency channels** 16
- **ANT Connector** N-Type connector x 2

LAN Interface

- **Ethernet** 10/100 Mbps, auto MDI/MDIX
- **Standard** IEEE 802.3, 802.3u, 802.3af/at, 802.3ab
- **Protection** 1.5-kV built-in magnetic isolation protection

General

- **LED Indicators** Status

Software

- **Network and Routing** DHCP server, NAT/PAT, VRRP, dynamic DNS client, DNS proxy, VLAN, QoS, DMVPN, NTP client/server, IGMP, BGP, OSPF, RIP, SMTP, SMTPS, SNMP v1/v2c/v3, backup routers, PPP, PPPoE, SSL, port forwarding, host port routing, Ethernet bridging, network server SSH, Web Browser
- **Configuration** HTTPS, SSH, VPN tunnels, SFTP, DMZ, firewall
- **Network Security** (IP filtering, MAC address filtering, inbound/outbound port filtering)
- **VPN tunnelling** Open VPN client and server and P2P, L2TP, PPTP, GRE, EasyVPN, IPSec with IKEv1 and IKEv2
- **Software package** Node-Red, LoRaWAN Network Server, Edgmlink

Mechanics

- **Dimensions (W x H x D)** 160 x 255 x 79.5 mm (6.2" x 10.04" x 3.13")
- **Mounting** Pole, wall
- **Weight** 1.3kg
- **Enclosure Rating** IP67
- **SD Card** 1 x Micro SD Card Slot

Environment

- **Operating Temperature** -40 ~ 75°C
- **Storage Temperature** -40 ~ 85°C
- **Operating Humidity** 10 ~ 95% RH

Dimensions

Unit: mm [inch]

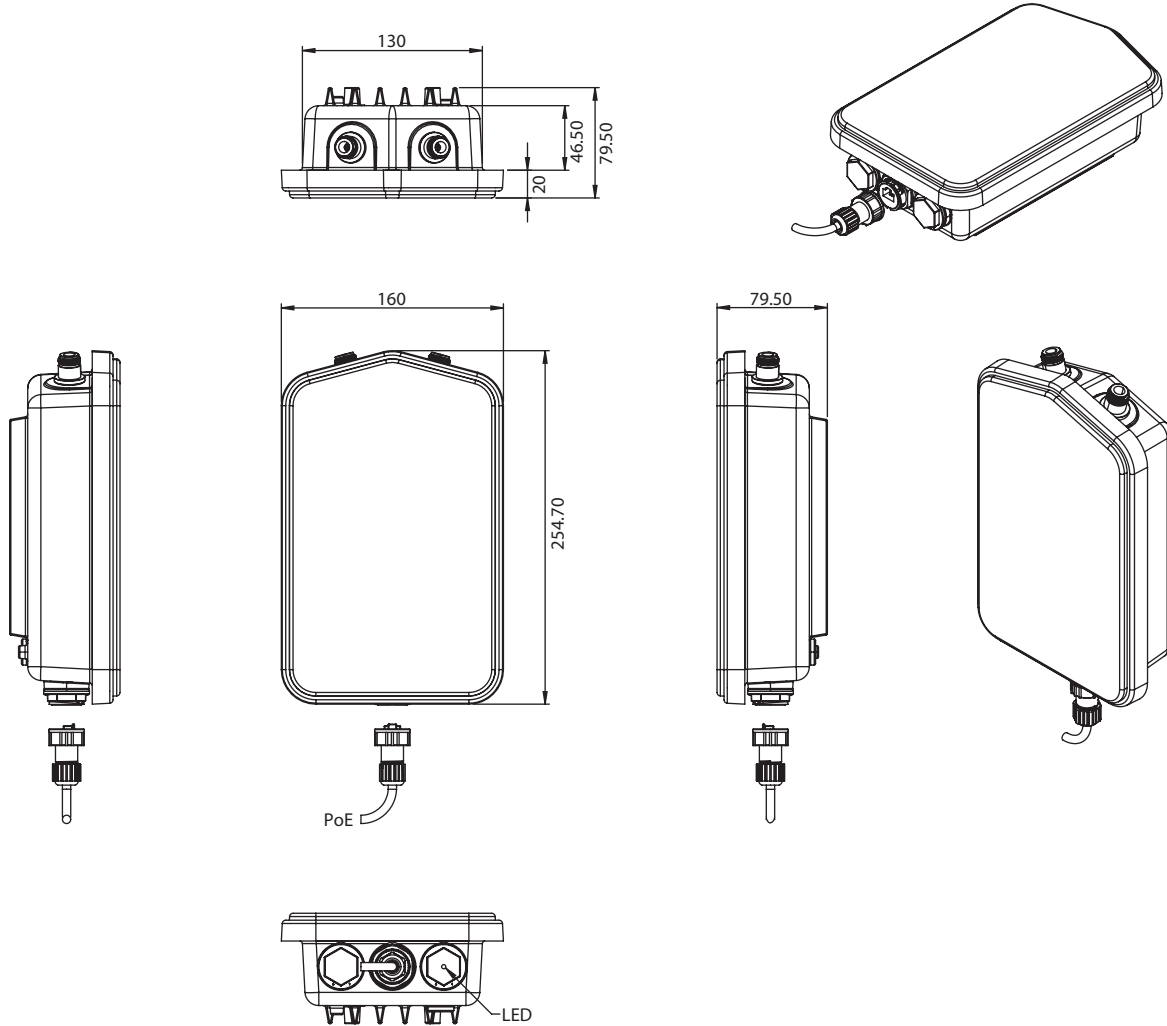

Ordering Information

- **WISE-6610P-DEA** 16channel Industrial LoRaWAN Gateway(EU868)
- **WISE-6610P-DNA** 16channel Industrial LoRaWAN Gateway(NA915)
- **WISE-6610P-DJA** 16channel Industrial LoRaWAN Gateway(JP923)
- **WISE-6610P-DTA** 16channel Industrial LoRaWAN Gateway(AS923)

Accessories

- **EKI-2701HP-AC-A** Gigabit IEEE 802.3at PoE+ Injector (without power cord)
- **1702002600** Power Cord for US, 183cm
- **1702002605** Power Cord for EU, 183cm
- **1700000237** Power Cord for JP, 183cm